

Small Scale Hydro Turbines

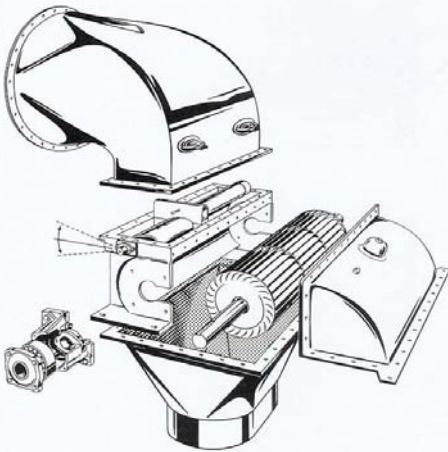

Hydro Turbines are a machine for converting the energy in a flowing stream of water to electricity. They are custom built to suit the head, or fall, and the volume of water that may be expected. Flow rates may alter significantly over the year, and heads can be low, hence a turbine that can operate effectively at very low heads and variable flow rates will offer the best overall solution.

The machine illustrated left operates between 1 to 200m head with water flows of 0.025 to 13 m³/s and power outputs of 1kW to 2MW. It is a simple, robust design for continuous operation over a period of decades and can be run without any special maintenance equipment.

The heart of the machine is the rotor, which has up to 37 blades made from bright-drawn sectional steel welded into end plates, which require careful balancing prior to final assembly. The rotor is centered

in relation to the turbine casing, capable of withstanding impact and freezing conditions. Apart from an annual grease change, the bearing requires no maintenance. For low head applications and where water flow rate fluctuates, the multi-cell turbine design with 1, 2 or 3/3rds of the rotor in operation enables maximum use of fluctuating water supplies to operate at optimum efficiency over 83% of it's range.

This type of machine is a 'free-stream' turbine with a wide operating range, as such the suction water column must be controllable if the turbine is to be constructed as a draft tube turbine, hence an adjustable valve regulates the vacuum in the turbine casing enabling heads of as little as 1m to be fully utilised. Designing the draft tube as a steel bend considerably reduces the costs of hydraulic engineering at low falls.

The inlet feed water is controlled by two balanced guide vanes which divide the water flow and direct it to smoothly the rotor. Both guide vanes can be adjusted independently either by automatic or manual controls and also serve as shut-off devices. This flow pattern has the advantage that debris is pressed between the vanes when the water enters and assisted by centrifugal force, is flushed out by the emerging water after half a revolution of the rotor, thus the 'self-cleaning' rotor never becomes clogged.

Small rivers and water courses often have reduced water flow for several months of the year. Whether or not power can be generated during that time depends on the efficiency characteristics of the particular turbine. Turbines with a high peak efficiency but poor partial load behaviour, produce less annual power output with a fluctuating water supply than turbines with a flat efficiency curve (see right). The variable area operation feature of this turbine enables the highest efficiency levels to be achieved over the entire operating range (see graph right) and from very low flow rates. The mean overall efficiency of this design is calculated at 80% for small and medium-sized power outputs, efficiencies of 87% are achievable for high-head units.

If you have a suitable resources and wish to pursue this solution, a site survey will be required before a quotation can be prepared.

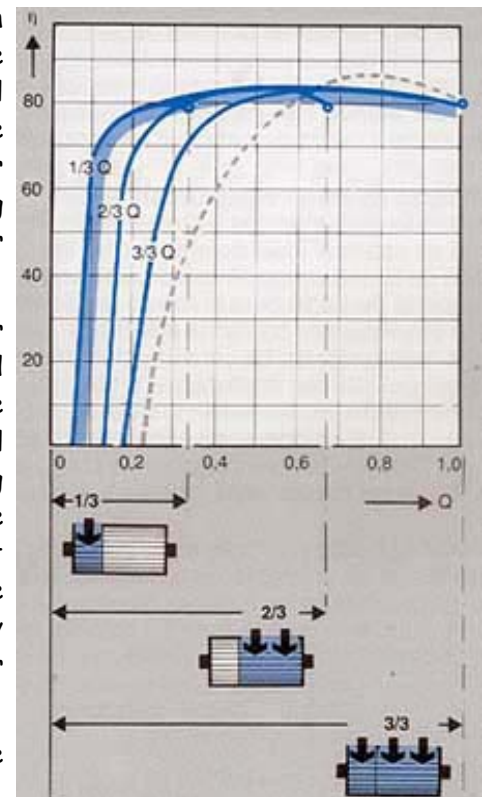

Planet Energy Solutions

Renewable Energy Systems

16 Carleton Rise, Welwyn, Hertfordshire, AL6 9RF

Tel. 01438 712398 ~ e-mail planetenergy@btinternet.com ~ www.planetenergy.co.uk

Design, Supply & Installation of Solar Thermal, Photovoltaic, Hydro & Wind Power, Biomass, Heat Pumps, Steam water & Ind. Fluids systems